

C O F F S H A R B O U R C I T Y C O U N C I L



Access and Mobility



Development Control Plan



PART 1 - INTRODUCTION

PREAMBLE

- This Development Control Plan (DCP) applies to new Class 3, 5,6,7,8,9 and 10a buildings within the Coffs Harbour Local Government Area. Changes of use, alterations and additions must also comply with the DCP.
- This plan came into force on 1 September 2001

OBJECTIVES

The controls in this DCP seek:

- To make people aware of their responsibilities under the Disability Discrimination Act, 1992;
- To increase community awareness of mobility handicaps affecting sections of the community and of the need for barrier free environmental design;
- To ensure that new development is accessible and useable for all, including those people with disabilities, to facilitate their full and independent participation in community life;
- To seek upgrading of existing buildings to the standards outlined in this plan; and
- To provide developers with clear guidance as to legal requirements and Council policy for access and mobility.

LEGAL REFERENCE

This plan is intended to complement and expand upon the provisions of the Building Code of Australia (BCA) and Coffs Harbour's Local Environmental Plan 2000 (as amended), which, together with parent State planning legislation and a number of State Environmental Planning Policies, provide the legal basis for assessment of development within the city.

It is to be read in association with the relevant DCP's and Information Sheets.

PROCEDURES

Step 1

Consult with Council on draft proposal



Step 2

Check if the proposed building *requires* access and/or facilities for people with disabilities under the DCP and the BCA (refer to Appendix A)



Step 3

If the proposal *requires* access and/or facilities for people with disabilities, ensure it meets the relevant Australian Standards (refer to Appendix B for a guide).



Step 4

Consider the Disability Discrimination Act – does the proposal satisfy the objectives of the act?



Step 5

Lodge development application with Council



When Development Approval has been given and the Construction Certificate has been issued



Step 6

Commence work in accordance with conditions of approval

PART 2 - LEGAL CONTEXT

THE DISABILITY DISCRIMINATION ACT (DDA), 1992

In 1992 the Commonwealth Government passed the DDA, which aims to eliminate bias against people with disabilities and protect their rights to equality with the rest of the community. The Act makes it unlawful to discriminate against people on the grounds of disability.

It promotes non-discriminatory access to premises, services and accommodation and the equitable and dignified use of services and premises. The DDA provides, in section 23(1) that:

“it is unlawful for a person to discriminate against another person on the ground of the other person’s disability or a disability of any of that other persons associates:

a) by refusing to allow the other person access to, or the use of any facilities in such premises that the public or a section of the public is entitled or allowed to use (whether for payment or not).

c) in relation to the provisions of means of access to such premises”

Its principles also extend to the quality of access, and not just to the physical parameters of conventional building legislation, which means that purely relying on the BCA is no longer sufficient for access and mobility issues.

Compliance with the BCA does not equate to compliance with the DDA.

The DDA is complaint-based legislation, so any person who feels discriminated under the DDA can lodge an action to the Human Rights and Equal Opportunity Commission.

THE BCA AND THE AUSTRALIAN STANDARD

The BCA and the Australian Standard AS1428 are the primary statutory controls regulating access and mobility issues in buildings.

The BCA regulates where access is required and calls up Part 1 of AS 1428 as the mandatory requirements for how access is provided. Part 4 (Tactile ground surface indicators) and Part 2 of AS1428 (which provides enhanced and additional requirements for buildings and facilities) are also relevant.

One of the key concepts of the BCA and AS 1428 Part 1 is to require the design of a **“Continuous Accessible Path of Travel” (CAPT)**, which may be defined as an uninterrupted path of travel to or within a building providing access to all areas normally used by the building’s occupants;

- a) from the allotment boundary at a point of entry from a road to the doorway at the entrance floor; and
- b) from any car park space provided for people with disabilities on the allotment (whether within or outside a building); and
- c) from any other building on the allotment to which access for people with disabilities is required by the BCA.

Section D3.3 of the BCA requires that the CAPT should **not** be obstructed by any stair, revolving door, escalator or other impediment that would prevent their use by people with disabilities.

PART 3 - DESIGN CONTROLS

EXISTING BUILDINGS

Where alterations/ extensions or changes of use are proposed to existing buildings for which public access is available, access for people with disabilities will be required.

There are three main upgrade options:

1. Upgrade the entire building to provide access for people with disabilities to the BCA standard.
2. Provide access for people with disabilities to and within the new work to the BCA standard; while maintaining the existing level of access to and within other parts of the building.
3. Where Council considers it unreasonable to provide access to the new work in accordance with the BCA, access may be allowed to a lesser standard.

Exemptions from the provisions of the BCA are provided for under section 23(2) of the DDA, which states that it is not unlawful to discriminate in relation to access to premises if:

- (a) the premises are so designed or constructed as to be inaccessible to a person with a disability; and*
- (b) any alteration to the premises to provide such access would impose unjustifiable hardship on the person who would have to provide that access."*

This concept may be used as a mechanism for the fair consideration of those instances where the access and mobility requirements are unreasonable, impractical or uneconomical, provided that adequate justification is provided. It is not relevant to new developments.

In order for Council to make an assessment for exemption under the "unjustifiable hardship" provisions, the applicant is to submit the following details:

- topographic restrictions;
- technical limits;
- safety, design and construction details;
- the costs involved in providing access; and
- the benefit for people with disabilities.

The level of public use of the building will in part determine the extent to which the building is to comply with the provisions of the BCA.

ROLE OF THE ACCESS ADVISORY COMMITTEE IN THE DEVELOPMENT ASSESSMENT PROCESS

In 1990, Coffs Harbour Council's Access Advisory Committee (CHAAC) was formed to act as an "advisory" body to the Council and other appropriate agencies on issues restricting access in the Coffs Harbour Local Government Area (LGA).

Any application which does not meet the requirements of the BCA will be referred to the CHAAC for comment.

Comments received from the CHAAC will be considered by Council in the assessment process.

ADDITIONAL CONSIDERATIONS FOR EXISTING BUILDINGS

A number of changes to the BCA and AS 1428.1 have been proposed within the Australian Building Codes Board's *Building Access Outcomes Report* (1998), including provisions for the sight and hearing impaired.

Council considers a number of these technical proposals appropriate for inclusion into this DCP. While they are not mandatory at this stage, Council will take them into consideration when assessing development applications.

Specialised Lifting Devices

The restricted use of specialised lifting devices may be permitted in certain circumstances, as outlined in the *Building Access Outcomes Report*. Low traffic, two level applications such as offices, restaurants and individual shops may provide access by the provision of:

- a) a lift complying with AS1735.16; or
- b) a stairway platform lift complying with AS 1735.7; or
- c) a low rise platform lift complying with AS 1735.14.

The platform is to be of sufficient size for a wheelchair and a carer. In addition, the lift is to be designed to enable independent use and operation.

The above provisions will only be provided where a report from a suitably qualified consultant is submitted, which certifies that it is impractical to provide access as per the BCA.

Note: Copies of these standards may be obtained from Standards Australia.

NEW BUILDINGS

The BCA sets out the access requirements by building class. Table D3.2 of Part D3 of the BCA sets out the requirements for access for people with disabilities. This part only applies to Class 3,5,6,7,8, 9 and 10a buildings.

The table applies to all development that requires Council consent, including the erection of new buildings, alteration and additions to existing buildings and change of use of existing buildings.

In general, buildings must be *accessible as required* by Table D3.2. Parts of buildings *required* to be *accessible* must comply with Part D3.2 and AS 1428.1.

This part also sets out the carparking requirements for people with disabilities by BCA Class, requirements for the identification of accessible facilities, services and features, for hearing augmentation and tactile indicators.

Part F2.4 of the BCA sets out the minimum sanitary facilities required for use by people with disabilities. Sanitary facilities must be provided in accordance with Table F2.4 for every class of building that is *required* to be *accessible* in accordance with Part D3.

These requirements are documented in Table 1 in Appendix A.

ADDITIONAL CONSIDERATIONS FOR ACCESS

Toilet Facilities

Where appropriate, sliding or pivotal doors may be required (in replacement of swinging doors) for accessible toilet facilities.

High use facilities should consider the installation of an emergency call button in accessible toilet facilities.

There should be an accessible unisex facility within every toilet block in a building. In addition, a facility for ambulant people with a disability should be provided within each male and female toilet block of sanitary compartments.

Where two or more facilities are provided, they should be of the opposite hand.

Where swing doors are provided, lever handles are to be installed.

Change Rooms

Baby change rooms are to be accessible and should be provided separately from other facilities.

Internal Access Provision

Access to all developments is required through the "principal public entrance" (in accordance with the BCA). In designing this access, consideration should be given to the provision of access within the building, in preference to external access structures.

DETAILED DESIGN REQUIREMENTS

The following section (refer to Appendix B) is a compilation of the major design and mobility aspects of the BCA and the Australian Standards.

A checklist has been prepared as a guide of how consistent the design of your proposal is with these standards. Compliance with these requirements will not automatically result in approval of your proposal. You will still need to demonstrate compliance with the DDA, 1992.

DISCLAIMER

Applicants are advised that compliance with this DCP may not exempt an action under the DDA. Applicants should seek their own legal advice in this regard.

APPENDIX A

REQUIREMENTS FOR ACCESS FOR PEOPLE WITH DISABILITIES

Table 1. Requirements for access for people with disabilities
(Source: BCA, 1996).

Classification of Buildings and Structures	Areas to be accessible (BCA Table D3.2)	Minimum sanitary facilities required for use by people with disabilities (BCA Table F2.4)	Number of carparking spaces required for people with disabilities (BCA Table D3.5)
<p>Class 3: Residential Buildings which are a common place of long term living (including boarding houses, hostels and accommodation for the aged) with a total floor area exceeding 300m² or more than 12 persons</p> <p>a) Common areas and unique features and services</p> <p>b) if the building or group of buildings contains sole-occupancy units –</p> <p>(i) For 1 to 20 units</p> <p>(ii) For more than 20 but not more than 45 units</p> <p>(iii) For each additional 30 units or part thereof</p>	<p>To and within –</p> <p>(i) the common areas on the storey incorporating the principal public entrance; and</p> <p>(ii) any facility required to be accessible; and</p> <p>(iii) not less than 1 of each room or area in which a unique service is provided or which has a unique feature</p> <p>To and within 1 sole – occupancy unit.</p> <p>To and within 2 sole-occupancy units.</p> <p>To and within 1 additional sole-occupancy unit. Where 2 or more accessible sole-occupancy units are required, they must be distributed as equitably as practical so as to be representative of the range of amenity available.</p>	<p>In every sole-occupancy unit for which access for people with disabilities is required, a minimum of one closet pan and washbasin and one shower is to be provided for use by people with disabilities.</p> <p>In accommodation other than sole occupancy units and other parts of the building to which access for people with disabilities is required –</p> <p>Where F2.1 and F2.3 (BCA) require 1-100 closet pans plus urinals - one wheelchair accessible unisex facility is required.</p> <p>Where F2.1 and F2.3 (BCA) require 101-200 closet pans plus urinals –</p> <p>a) two wheelchair accessible unisex facilities; or</p> <p>b) one wheelchair accessible unisex facility and one wheelchair accessible closet pan & washbasin for each sex</p>	<p>(a) For boarding houses, guest houses, hostels, lodging houses, backpackers accommodation or the residential part of a hotel or motel, the number of carparking spaces required for people with disabilities is to be calculated by multiplying the total number of carparking spaces by the –</p> <p>(i) percentage of the accessible sole-occupancy units to the total number of sole-occupancy units; or</p> <p>(ii) the percentage of beds to which access for people with disabilities is provided to the total number of beds provided.</p>

<p>c) If accommodation is provided for more than 10 persons, other than in <i>sole-occupancy units</i> –</p> <p>(iv) Less than 49 beds</p> <p>(v) Between 49 & 99 beds</p> <p>(vi) More than 99 beds</p>	<p>To 2 beds</p> <p>To 4 beds</p> <p>To 6 beds</p>	<p>Where F2.1 and F2.3 (BCA) require over 200 closet pans plus urinals –</p> <p>a) two wheelchair accessible unisex facilities or one wheelchair accessible unisex facility & one wheelchair accessible closet pan & washbasin for each sex and</p> <p>b) one additional wheelchair accessible unisex facility or one wheelchair accessible closet pan and washbasin for each sex for each additional 100 facilities normally required.</p> <p>Where F2.1 and F2.3 require 1 or more showers, one accessible shower for each 10 showers or part thereof, but no less than one for use by both sexes is to be provided.</p> <p>Adequate facilities for disposal of sanitary towels must be provided. A unisex facility must also have a shelf.</p>	<p>The calculated number to be taken to the next whole figure.</p> <p>c) For the residential part of a school, accommodation for the aged, disabled or children, residential part of a <i>health-care building</i> which accommodates members of staff or the residential part of a <i>detention centre</i>, 1 space for every 100 carparking spaces is to be provided.</p>
--	--	---	---

<p>Class 5, 6, 7 and 8: Commercial developments (including commercial premises, shops, refreshment rooms) and Industrial developments (including industries and warehouses)</p>	<p>To and within the entrance floor; and</p> <ul style="list-style-type: none"> (i) any other floor to which vertical access by way of a ramp; (ii) step ramp or kerb ramp complying with AS 1428.1 or a passenger lift is provided. 	<p>For buildings to which access by people with disabilities is <i>required</i>, the requirements outlined for Class 3 buildings apply.</p>	<p>For Class 5, 7 & 8 buildings 1 space is required for every 100 carparking spaces or part thereof.</p> <p>For Class 6 buildings:</p> <ul style="list-style-type: none"> (i) where up to 1000 carparking spaces are provided, 1 space for every 50 carparking spaces or part thereof is required. (ii) For each additional 100 carparking spaces or part thereof in excess of 1000 spaces, 1 space is required.
<p>Class 9a: Health-care buildings (such as hospitals, nursing homes and day surgery clinics)</p>	<p>To and within all areas normally accessible to the public, patients or staff.</p>	<p>For buildings to which access by people with disabilities is <i>required</i>, the requirements outlined for Class 3 buildings apply.</p>	<p>Class 9a):</p> <ul style="list-style-type: none"> a) Hospitals (non-outpatient areas) – 1 space for every 100 carparking spaces or part thereof b) Hospitals (outpatient areas); where up to 1000 carparking spaces is provided – 1 space for every 50 carparking spaces or part thereof. For each additional 100 carparking spaces or part thereof in excess of 1000 carparking spaces – 1 space. c) Nursing homes – 1 space for every 100 carparking spaces or part thereof. d) Clinic or day surgery not forming part of a hospital – 1 space for every 100 carparking spaces or part thereof.

<p>Class 9b: An assembly building not being a school or an early childhood centre</p>	<p>To and within every auditorium but not to every tier or platform; and</p> <ul style="list-style-type: none"> (i) the main entrance to the auditorium; and (ii) if fixed seating is provided, not less than one wheelchair space for each 100 persons or part thereof, with a minimum of 2 spaces, up to 200 persons, and an additional space for each additional 200 persons or part thereof by which the number of persons exceeds 200; and (iii) all other areas normally used by the occupants. 	<p>For buildings to which access by people with disabilities is <i>required</i>, the requirements outlined for Class 3 buildings apply.</p>	<p>Where up to 1000 carparking spaces are provided, 1 space for every 50 carparking space or part thereof is required. For each additional space in excess of 1000 spaces, 1 space for every 50 carparking spaces is required.</p>
<p>A school</p>	<p>To and within</p> <ul style="list-style-type: none"> (i) all areas normally used by the occupants, including staff, students and visitors, if no alternative similar facilities to be provided in that area are <i>accessible</i> elsewhere in the school; and (ii) any other floor to which vertical access by way of a ramp, step ramp or kerb ramp complying with AS1428.1, or a passenger lift is provided. 		<p>1 space for every 100 carparking spaces or part thereof.</p>

<p>Class 10a: an outbuilding</p>	<p>To and within buildings containing any of the following –</p> <ul style="list-style-type: none"> (i) Sanitary facilities, showers, handbasins, changeroom facilities or the like. (ii) A unique service or feature, such as a public shelter or the like, which is located in an <i>accessible</i> area. 	<ul style="list-style-type: none"> a) Where sanitary facilities are provided – not less than 1 wheelchair <i>accessible</i> unisex facility. b) Where sanitary facilities containing more than one <i>sanitary compartment</i> are provided for the general public in addition to the wheelchair <i>accessible</i> unisex facility – not less than 1 <i>sanitary compartment</i> for each sex, suitable for an ambulant person with a disability. c) Where shower facilities are provided, not less than 1 <i>accessible</i> shower suitably located for use by both sexes. 	<p>Provide parking in accordance with the development type associated with class 10a buildings.</p>
---	---	--	---

APPENDIX B

DETAILED DESIGN REQUIREMENTS CHECKLIST

DETAILED DESIGN REQUIREMENTS

The following section is a compilation of the major access and mobility design aspects of the BCA, the Australian Standards and other guidelines produced by the Human Rights and Equal Opportunity Commission.

By completing this checklist, you will have a guide of how consistent the design of your proposal is with the standards.

1 WALKWAYS, RAMPS AND LANDINGS

(Australian Standard 1428.1, 1998)

Applicable (Please tick)

Non-applicable (Please tick)

1.1	General	Complies	
		Yes	No
a	Are all the normal paths of travel to the building and all areas of the building accessible to disabled persons (NB: No steps with a maximum construction tolerance of 5mm between abutting surfaces?)	<input type="checkbox"/>	<input type="checkbox"/>
b	Does the walkway, path or landing have:	<input type="checkbox"/>	<input type="checkbox"/>
	<ul style="list-style-type: none"> ❖ An unobstructed width of 1000mm ❖ An unobstructed vertical height of not less than 2000mm? 	<input type="checkbox"/>	<input type="checkbox"/>
c	Are the walkways and paths smooth and non-slip and have crossfalls or cambers less than 1 in 40?	<input type="checkbox"/>	<input type="checkbox"/>
d	Is provision made for people with visual impairment by the provision of:		
	❖ straight ramps/ walkways;	<input type="checkbox"/>	<input type="checkbox"/>
	❖ tactile indicators at the edges of the path, the end of the ramps and at changes of gradient; and	<input type="checkbox"/>	<input type="checkbox"/>
	❖ smooth transitions between sections?	<input type="checkbox"/>	<input type="checkbox"/>
1.2	Walkways		
a	Is the maximum gradient 1 in 20?	<input type="checkbox"/>	<input type="checkbox"/>
b	Are landings provided at intervals not exceeding –		
	<ul style="list-style-type: none"> ❖ Walkway gradients of 1 in 33 — 25m? ❖ Walkway gradients of 1 in 20 — 14m? 	<input type="checkbox"/>	<input type="checkbox"/>
Note: a	for walkway gradients between 1 in 33 and 1 in 20, landings should be provided at intervals by linear interpolation	<input type="checkbox"/>	<input type="checkbox"/>
	b landings are not required where walkway gradients are flatter than 1 in 33		
c	Are kerbs and handrails provided on both sides when the ground falls away within 600mm from the walkway?	<input type="checkbox"/>	<input type="checkbox"/>

1.3 Ramps

- a All ramps exceeding 1520mm have a maximum gradient of 1 in 14?
- b Are landings provided on ramps at intervals not exceeding:
- ❖ 14m for a 1 in 19 ramp?
 - ❖ 9m for a 1 in 14 ramp?
- Note: for ramp gradients between 1 in 19 and 1 in 14, landings are to be provided at intervals which shall be obtained by linear interpolation
- c Are landings provided at each change of direction?
- d Are ramps provided with continuous kerbs and handrails on both sides of the ramp in accordance with Figure 1?

1.4 Stairways

- a Are the top or bottom steps of a flight of stairs located outside of the required circulation spaces?
- b Do all steps have non-slip surfaces?
- c Is there a strip of contrasting colour (eg a painted white line) at least 25mm wide on the tread at the nosing?
- d Are the handrails designed as shown in Figure 1?
- e Is the handrail continuous, and if not, is there a raised tactile warning in the form of a domed button provided on the top of the handrail 150mm from the end of the horizontal surface of the handrail?

1.5 Landings

- a Does the length of landing have a minimum length of 1200mm?
- b If there is an adjacent doorway to the landing, does the circulation space comply with 1428.2 (Clause 7.3)?

1.6 Kerb ramps and step ramps

- a Is the kerb ramp not greater than 1520mm in length with a gradient of not greater than 1 in 8?
- b Is there an unobstructed landing of 1330mm at the top of the kerb ramp?
- c Where transverse pedestrian traffic is anticipated are the sides of kerb ramps and step ramps graded plane surfaces?
- NB This requirement is not necessary if a suitable 900mm high barrier is erected.
- d Have the requirements of Clause 7.3 circulation space at doorways of AS 1428.1 been considered in designing the width of the ramp?
- e Do opposite ramps align with each other?
- f Do they colour contrast with floor surfaces?

2 HANDRAILS AND GRABRAILS

Australian Standard 1428.1 – Clause 6 and AS 1428.3

Applicable (Please tick)

Non-applicable (Please tick)

2.1	General	Complies	
		Yes	No
a	Are the cross-sections of the handrails circular, with a diameter between 30mm and 50mm, for not less than 270 degrees around the uppermost surface?	<input type="checkbox"/>	<input type="checkbox"/>
b	Is there a 50mm clearance (max 60mm clearance) between handrails or grabrails and an adjacent wall surface? NB The clearance should extend 600mm above top of rail.	<input type="checkbox"/>	<input type="checkbox"/>
c	Is the top of the handrail not less than 865mm nor more than 1000mm above the nosing of the tread or the plane of the finished floor?	<input type="checkbox"/>	<input type="checkbox"/>
d	Are handrails securely fixed and rigid extending past the first and last steps 300mm and their ends returned away to a side wall or turned downwards for a distance of not less than 100mm?	<input type="checkbox"/>	<input type="checkbox"/>
e	Are handrails and grab-rails free of sharp corners or obstructions?	<input type="checkbox"/>	<input type="checkbox"/>
g	Do grabrails have an outside diameter of not less than 30mm and not more than 40mm?	<input type="checkbox"/>	<input type="checkbox"/>
h	Are kerbs and handrails provided in accordance with Figures 1-3?	<input type="checkbox"/>	<input type="checkbox"/>
i	Are handrails of a contrasting colour to the surrounding environment?	<input type="checkbox"/>	<input type="checkbox"/>

Figure 1: Ramp and Stairwell Handrails
 Source: Australian Standard 1428.1 - 1998

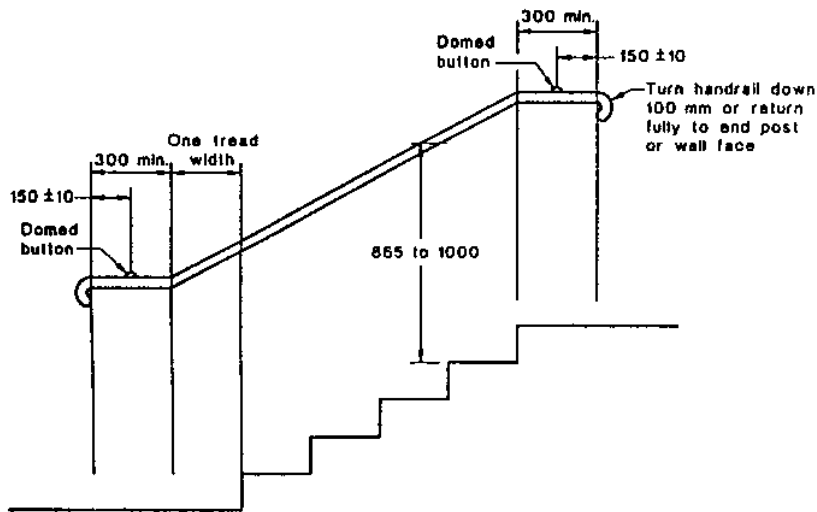
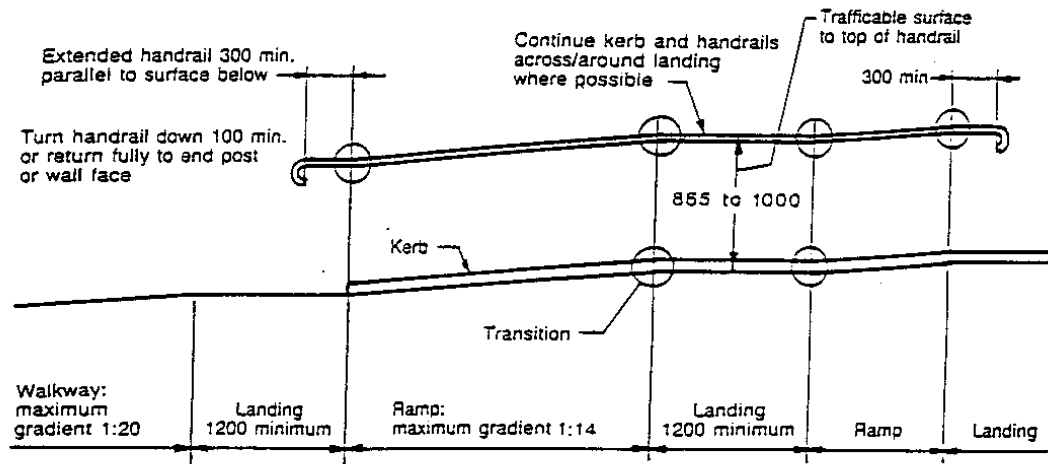

- NOTES:**
- 1 The dimensions indicating the heights of handrails are taken from the nosing of the tread to the top of the handrail.
 - 2 The 300 mm extension is not required where the handrail is continuous, e.g. on the inside of an intermediate landing.

DIMENSIONS IN MILLIMETRES

Figure 2: Kerbs
 Source: Australian Standard 1428.1 - 1998

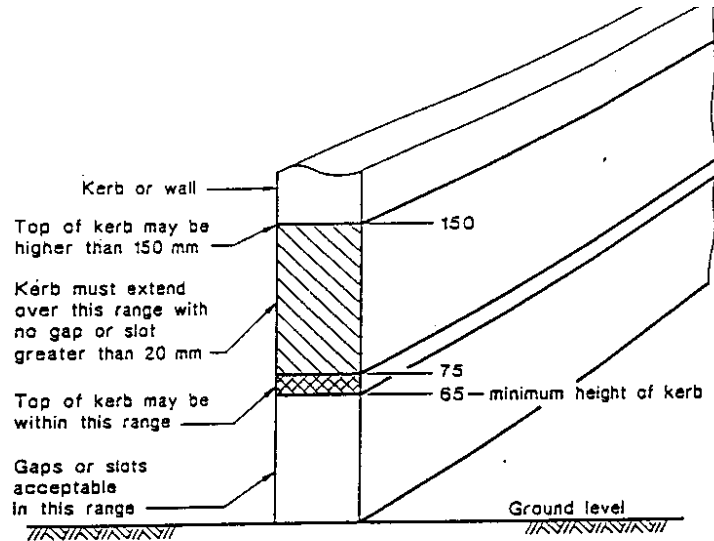
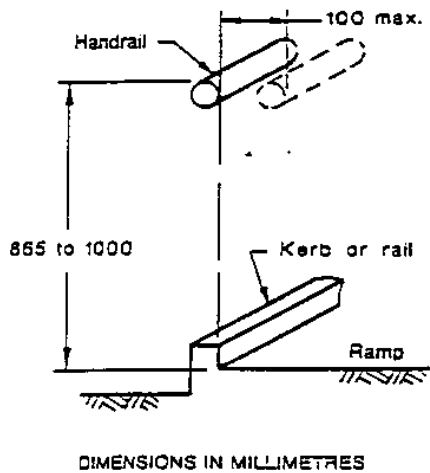

Figure 3: Location of Kerb in Relation to Handrail
 Source: Australian Standard 1428.1 - 1998



3 DOORWAYS, DOORS AND DOOR CIRCULATION SPACE

Applicable (Please tick)

Non-applicable (Please tick)

3.1	Doorway and Doors (Source: AS1428.1)	Complies	
		Yes	No
a	Is there an entrance door which provides for the safe, equitable and dignified access for use by the general public and which is incorporated in a continuous accessible path of travel? NB This access should be the principal access door, be sheltered and the requirements of the provision of required exit doors under the Building Code of Australia should be taken into consideration.	<input type="checkbox"/>	<input type="checkbox"/>
b	Is the entrance free of steps/lips?	<input type="checkbox"/>	<input type="checkbox"/>
c	Where a revolving or turnstile door is installed, is an alternative hinged or sliding door also provided?	<input type="checkbox"/>	<input type="checkbox"/>
d	Are all doors capable of being used by people in wheelchairs? AS 1428.1 specifies a minimum door width of 800mm.	<input type="checkbox"/>	<input type="checkbox"/>
e	Are glass doors clearly marked with a 75mm wide line between 900mm and 1000mm above the floor eg a clearly visible or contrasting colour?	<input type="checkbox"/>	<input type="checkbox"/>
f	Is the door able to be unlocked and opened with one hand? NB Lever handles are preferred. Delayed action door closers should be used where door closers are required.	<input type="checkbox"/>	<input type="checkbox"/>
g	Are handles mounted between 900mm - 1100mm above the floor and in a contrasting colour to that of the door?	<input type="checkbox"/>	<input type="checkbox"/>
h	Are handles between 35 and 45mm from the door face?	<input type="checkbox"/>	<input type="checkbox"/>
i	Are handles in sliding doors 60mm clear of the jamb lining?		
j	Are door jambs or door frame of a colour or material in contrast with the door?	<input type="checkbox"/>	<input type="checkbox"/>
k	Is there a tactile surface change to indicate a doorway or entry point?	<input type="checkbox"/>	<input type="checkbox"/>

3.2	Circulation Spaces (Source: AS1428.1)	Complies	
		Yes	No
a	Has a minimum clear floor, or ground, space of 800mm x 1300mm been provided to accommodate a single stationary wheelchair?	<input type="checkbox"/>	<input type="checkbox"/>
b	Are circulation spaces provided as follows:		
	❖ Not less than 2070mm (in direction of travel) by 1540mm (wide) space for 180° wheelchair turn?	<input type="checkbox"/>	<input type="checkbox"/>
	❖ Not less than 2250mm by 2250mm space to make 360° wheelchair turn?	<input type="checkbox"/>	<input type="checkbox"/>
c	Have the following passing spaces for wheelchairs been applied:		
	❖ The minimum width of 1800mm is provided for two wheelchairs to pass each other?	<input type="checkbox"/>	<input type="checkbox"/>
	❖ Where passing spaces are less than 1800mm wide, are passing spaces at intervals of 6m provided?	<input type="checkbox"/>	<input type="checkbox"/>

Figure 4: Minimum Clear Floor Space for Wheelchairs

Source: Australian Standard 1428.1 - 1998

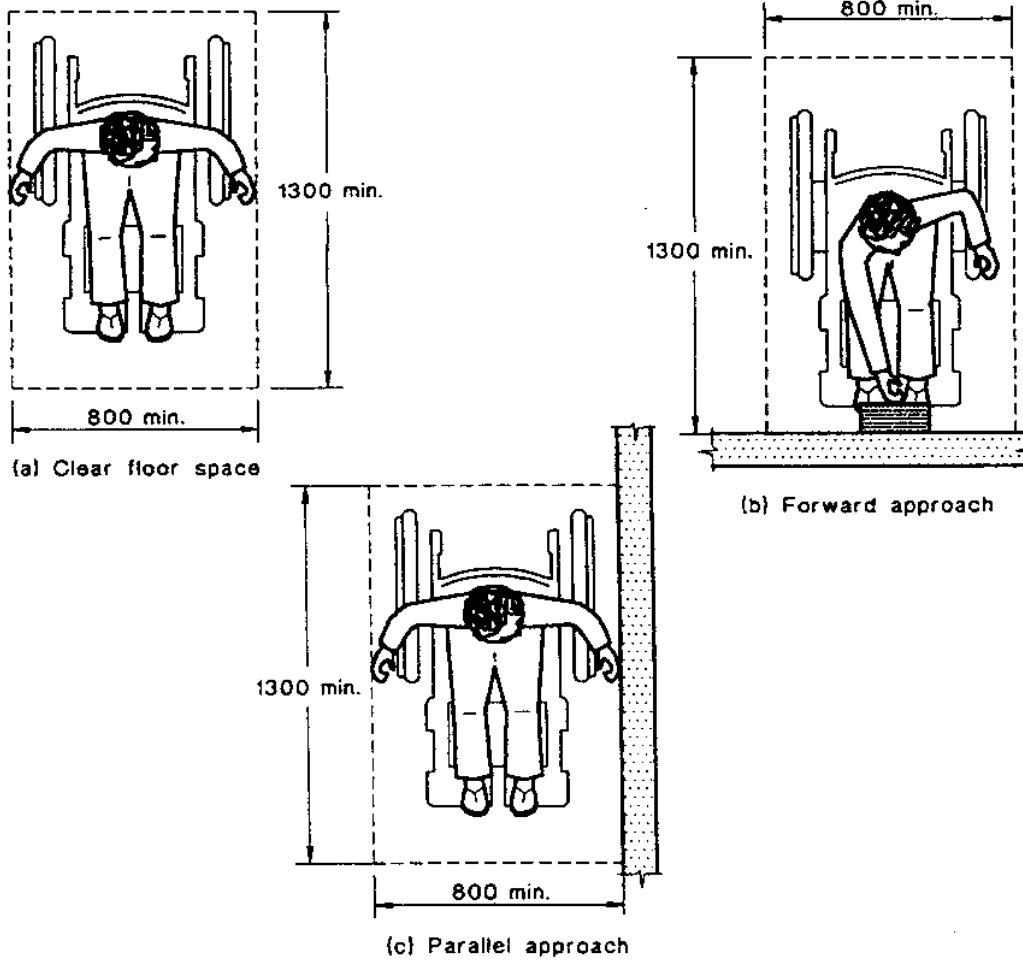

DIMENSIONS IN MILLIMETRES

4 SANITARY FACILITIES

Applicable (Please tick)

Non-applicable (Please tick)

4.1	Toilets (Source: AS1428.1)	Complies	
		Yes	No
a	Are accessible toilets on a continuous accessible path of travel and within the general vicinity of the toilet area of the building?	<input type="checkbox"/>	<input type="checkbox"/>
b	Are accessible unisex sanitary facilities provided and located so that access does not necessitate traversing an area reserved for one sex only, or alternatively are separate WCs provided for use by females and males?	<input type="checkbox"/>	<input type="checkbox"/>
c	Is the toilet compartment large enough to provide for an adequate circulation space (Figure 5)?	<input type="checkbox"/>	<input type="checkbox"/>
d	Do all publicly accessible toilets contain wall mounted baby change facilities, preferably with a side hinge to minimise the intrusion into the circulation space?	<input type="checkbox"/>	<input type="checkbox"/>
e	Can the door be opened or removed from the outside in case of an emergency (open outward or slide)?	<input type="checkbox"/>	<input type="checkbox"/>
f	Is the door fitted with an 'in-use' indicator ?	<input type="checkbox"/>	<input type="checkbox"/>
g	Is the front of the toilet pan located at a minimum of 800 mm from the rear wall or 600 mm from any rear wall mounted fixture or obstruction?	<input type="checkbox"/>	<input type="checkbox"/>
h	Are there side and rear grabrails provided adjacent to the toilet pan, and are they between 800mm and 810mm from the floor (Figure 6)?	<input type="checkbox"/>	<input type="checkbox"/>
l	Is the centre of the toilet pan located at minimum of 450 to 460mm from the edge of any back wall mounted fixture or obstruction?	<input type="checkbox"/>	<input type="checkbox"/>
J	Is the toilet lid fitted and supported between 100 and 150 beyond vertical, to act as a backrest?	<input type="checkbox"/>	<input type="checkbox"/>
k	Are there both paper towels and warm air hand dryers provided?	<input type="checkbox"/>	<input type="checkbox"/>
l	Is the flush control and toilet paper dispenser designed in accordance with Figure 7?	<input type="checkbox"/>	<input type="checkbox"/>
m	Have urinals been constructed without a hob or step?	<input type="checkbox"/>	<input type="checkbox"/>
n	Do taps clearly show hot/cold symbols?	<input type="checkbox"/>	<input type="checkbox"/>

4.2 Washbasins and Fixtures (Source: AS1428.1 – 1993)			
a	Have washbasins been designed and sited so as to maintain adequate circulation space in accordance with AS 1428.1 Clause 10.3 as shown on Figure 8)?	<input type="checkbox"/>	<input type="checkbox"/>
b	Are any exposed hot water supply pipes insulated or located so as not to pose a hazard?	<input type="checkbox"/>	<input type="checkbox"/>
c	Are taps fitted with lever handles and is the hot water tap located to the left of the cold?	<input type="checkbox"/>	<input type="checkbox"/>
d	Is there a vertical mirror, 350 mm wide by 950 mm, centred and mounted right over the washbasin?	<input type="checkbox"/>	<input type="checkbox"/>
e	Are other fittings, such as shelves and soap and towel dispensers, installed with their operative component or outlet between 900 mm and 1100 mm above the floor?	<input type="checkbox"/>	<input type="checkbox"/>
f	Are any clothes hanging fittings located between 1200 mm and 1350 mm above the floor, and more than 500 mm from an internal corner?	<input type="checkbox"/>	<input type="checkbox"/>
4.3 Showers (Source: AS1428.1)			
a	Does the shower cubicle allow for someone to bend over comfortably or move out of the shower stream while washing?	<input type="checkbox"/>	<input type="checkbox"/>
b	Does the shower recess contain fittings (grabrail, soap holder and folding seat) which meet the dimensions specified in Figures 9 and 10?	<input type="checkbox"/>	<input type="checkbox"/>
c	Is the shower and bathroom floor self-draining, non-slip and without a lip or hob?	<input type="checkbox"/>	<input type="checkbox"/>
d	Are shower controls easy to use of a contrasting colour to the background and a maximum of 1100mm above the floor?	<input type="checkbox"/>	<input type="checkbox"/>
e	Is there a shower foldable seat provided that is non-slip, self-draining with rounded edges and hinged, with fastenings and materials capable of withstanding a force of 1100N ?	<input type="checkbox"/>	<input type="checkbox"/>

4.3	Showers (continued)	Complies	
		Yes	No
f	Can the shower screen be opened or removed from the outside in an emergency?	<input type="checkbox"/>	<input type="checkbox"/>
g	Does the shower head:		
	❖ Allow for hand-held usage (portable)?	<input type="checkbox"/>	<input type="checkbox"/>
	❖ Have a device fitted to the wall allowing various angles and heights?	<input type="checkbox"/>	<input type="checkbox"/>
	❖ Have a flexible hose attached?	<input type="checkbox"/>	<input type="checkbox"/>
h	Are two clothes hanging fittings provided within 600mm of the seat?	<input type="checkbox"/>	<input type="checkbox"/>
	Note: a tap lever handles are preferred, with hot water to the left of cold; b when the foldable seat is in folded position it should not cause any hazard.		
i	Are glass shower screens clearly marked with a 75mm wide line between 900mm and 1000mm above the floor in a clearly visible and contrasting colour?	<input type="checkbox"/>	<input type="checkbox"/>

Figure 5: Circulation Space in Toilets
 Source: Australian Standard 1428.1 - 1998

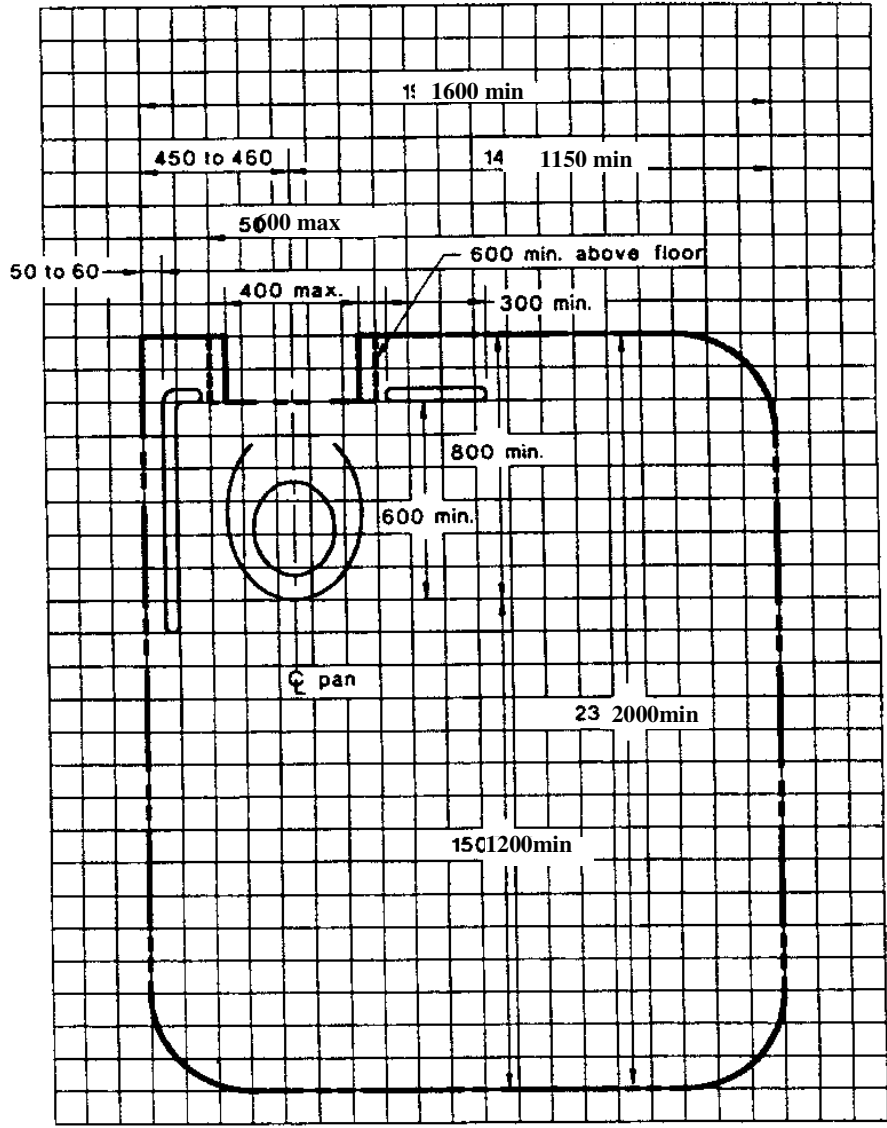

Grid 100 x 100

LEGEND:
 - - - - - Circulation space

NOTE: Mirror reverse is equally acceptable.

DIMENSIONS IN MILLIMETRES

Figure 6: Toilet Grabrail Locations
 Source: Australian Standard 1428.1 - 1998

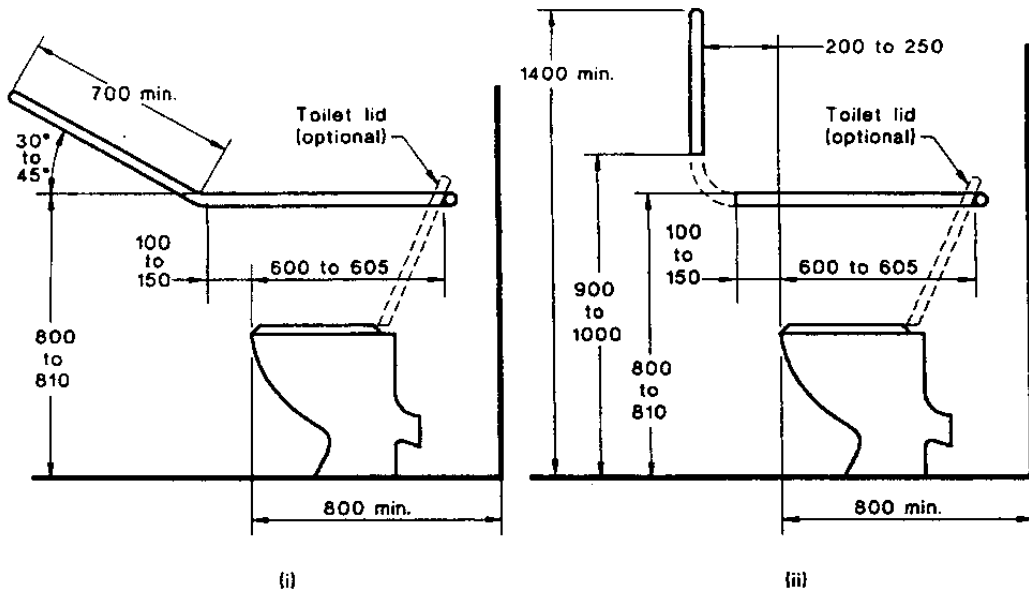

(d) Side view showing optional systems for grabrail at sides of pan

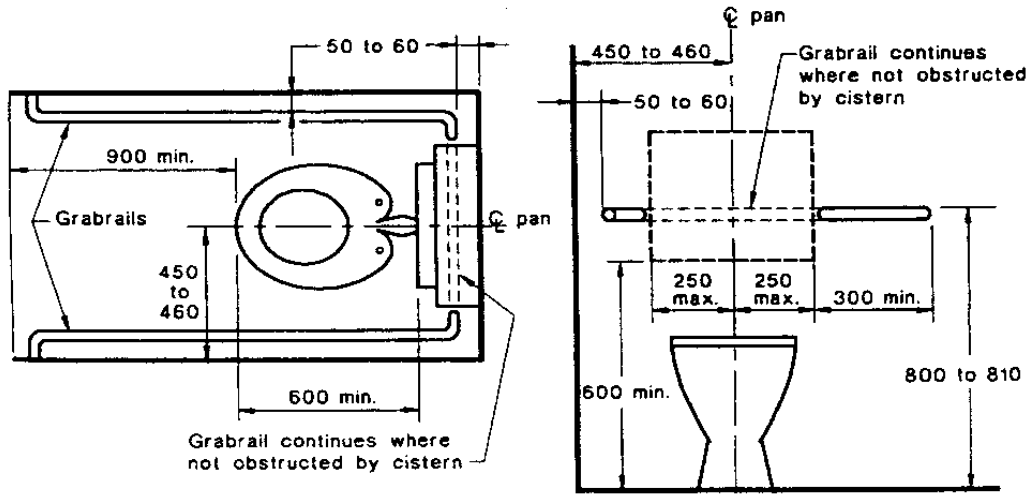

(e) For people with ambulant disabilities — top view

(f) Grabrail at back of pan and sectional view of grabrail at side of pan

DIMENSIONS IN MILLIMETRES

Figure 7: Toilet Fitting Locations
 Source: Australian Standard 1428.1 - 1998

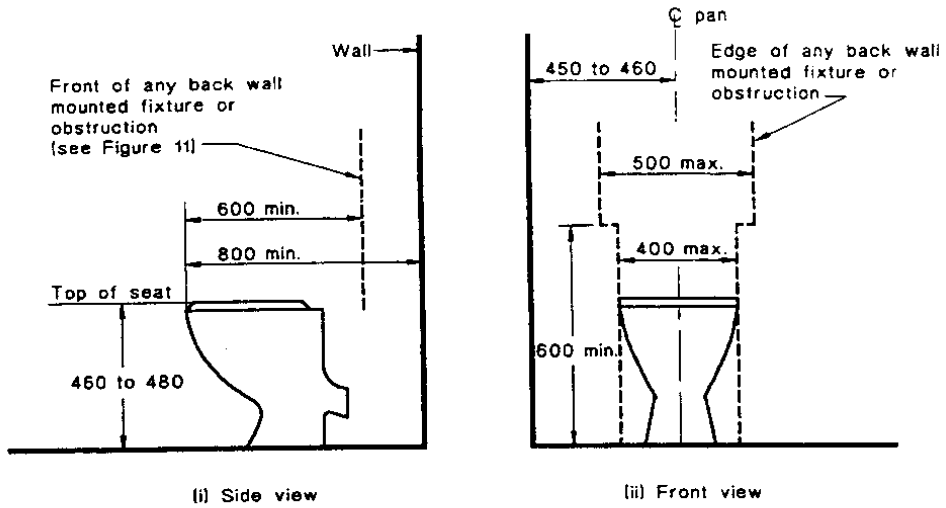

- NOTES:
 1 For the purpose of dimensioning, the front of the WC pan has been taken as the datum plane.
 2 The dimension of 800 mm from the front of the WC pan to the wall is a critical dimension.

(a) Pan clearances, seat height and seat width

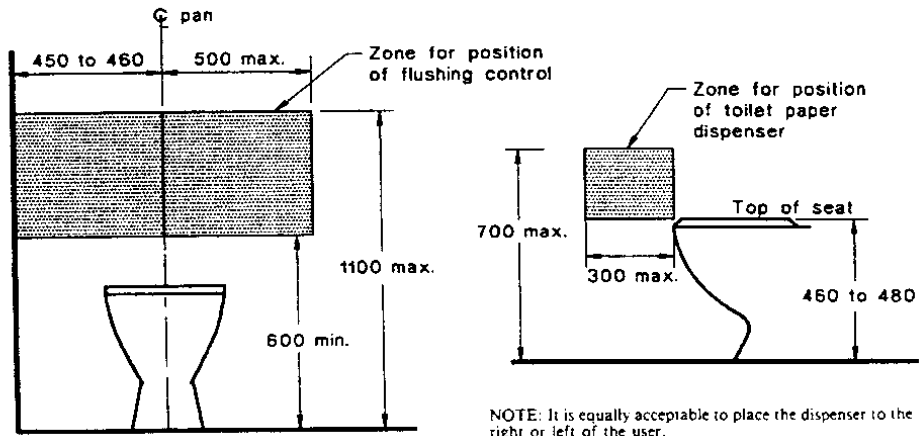

NOTE: It is equally acceptable to place the dispenser to the right or left of the user.

(b) Zone for position of flushing control

(c) Zone for position of toilet paper dispenser

DIMENSIONS IN MILLIMETRES

Figure 8: Washbasin and Fixtures
 Source: Australian Standard 1428.1 - 1998

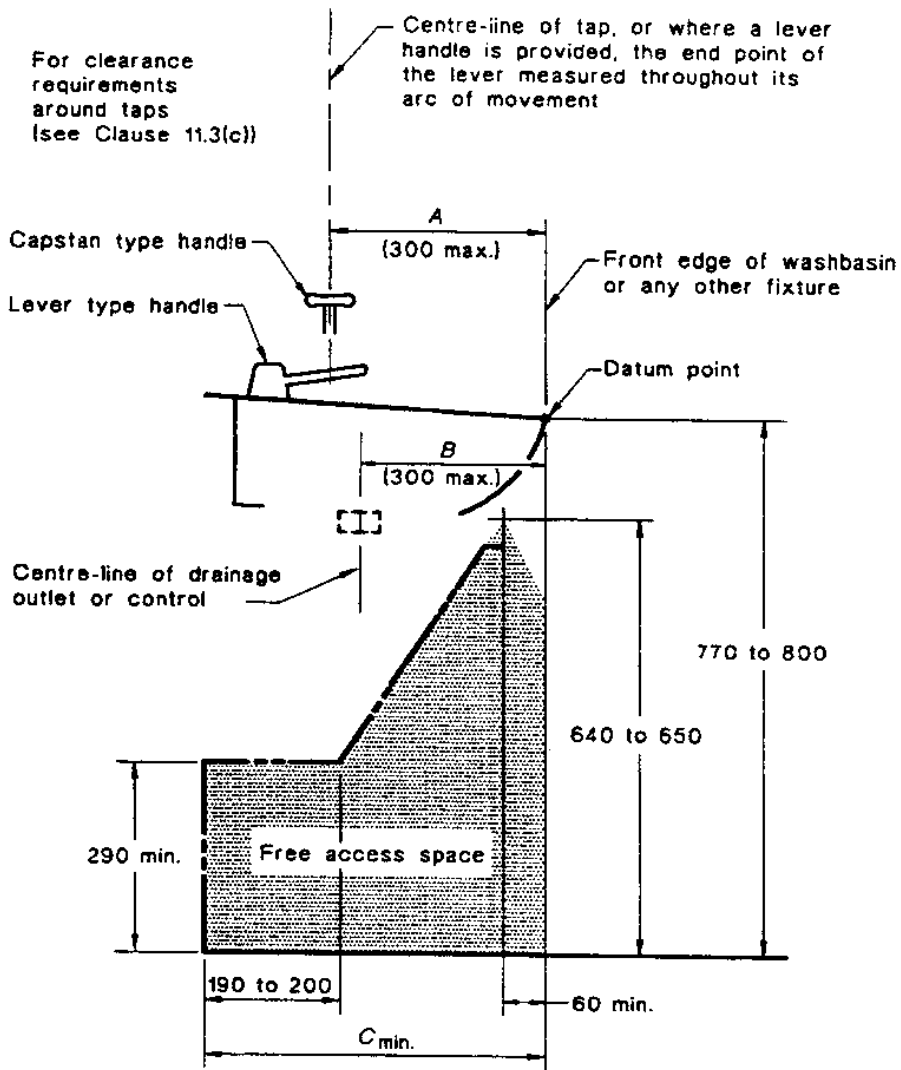

LEGEND:

$C_{min.} = \text{(the greater of A and B)} + 190$

----- Outer limits of obstructions beneath the washbasin

NOTE: The dimensions of the unobstructed space beneath the washbasin are critical dimensions.

DIMENSIONS IN MILLIMETRES

Figure 9: Shower Design
 Source: Australian Standard 1428.1 - 1998

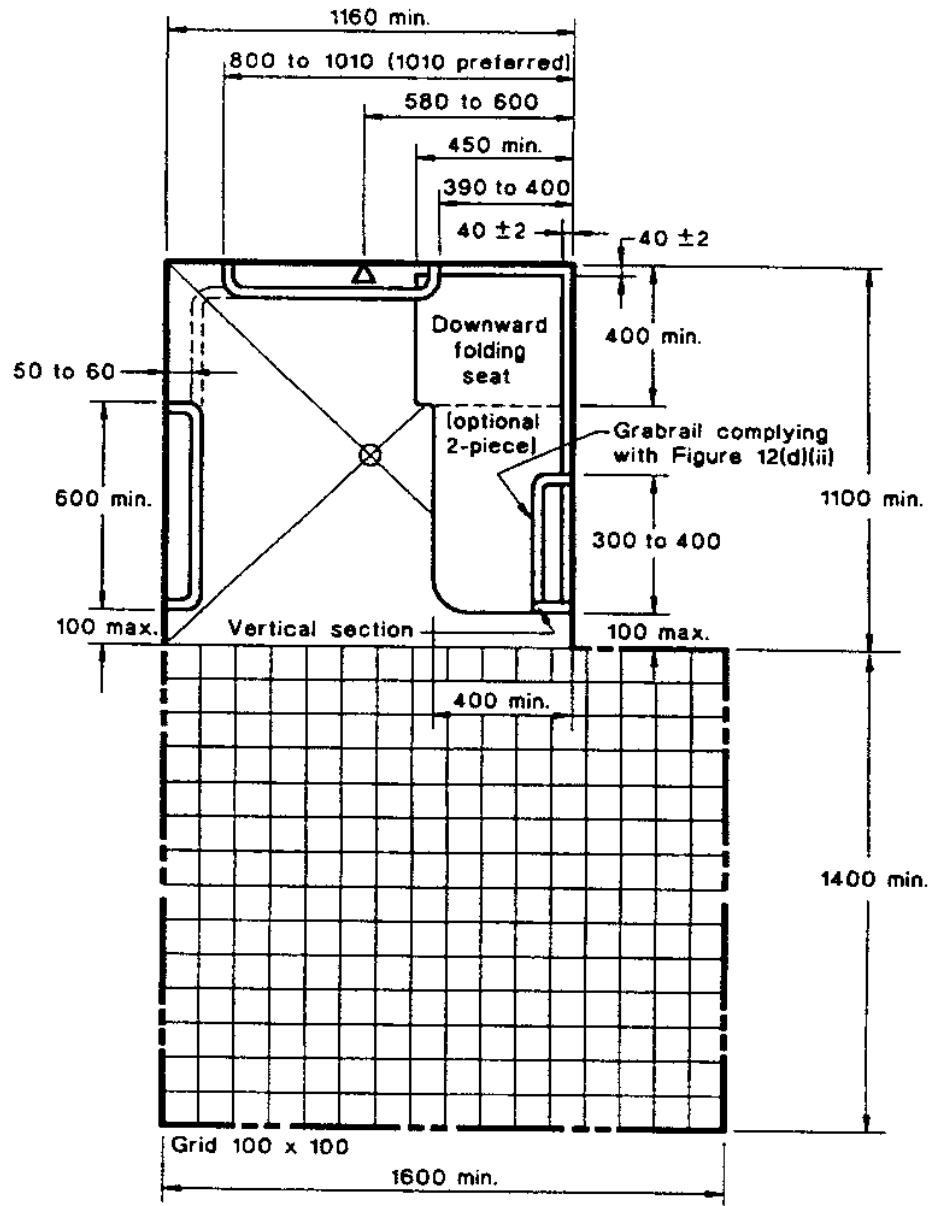

(b) Shower recess with three walls

LEGEND:
 - - - - - Circulation space

NOTE: Mirror reverse is equally acceptable.

DIMENSIONS IN MILLIMETRES

Figure 10: Shower Recess Fittings
 Source: Australian Standard 1428.1 - 1998

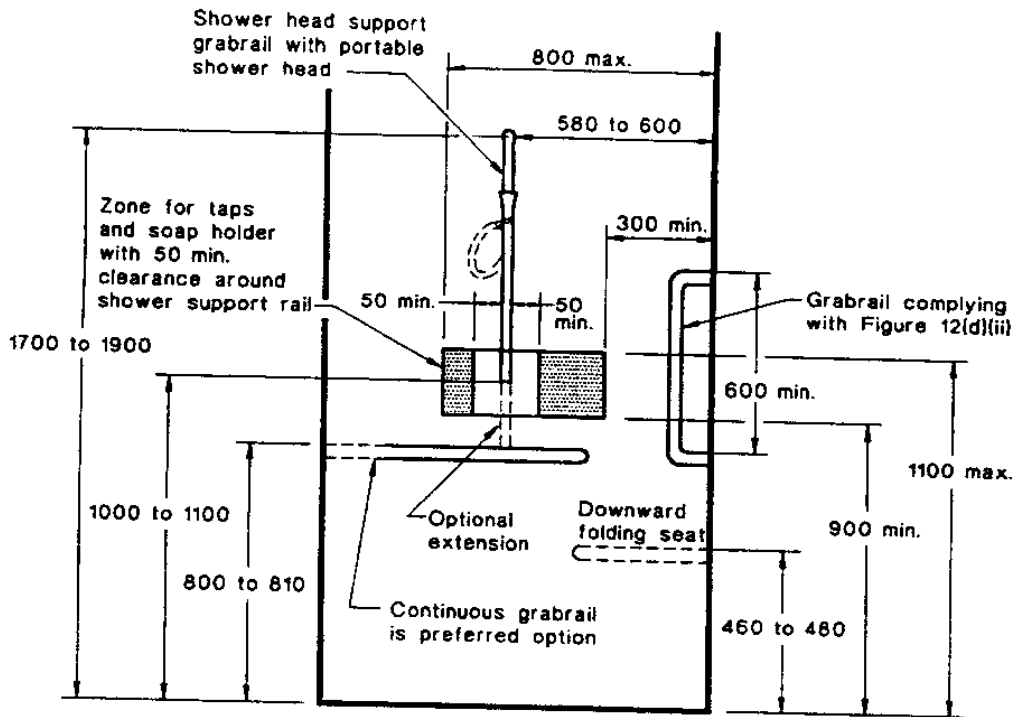

DIMENSIONS IN MILLIMETRES

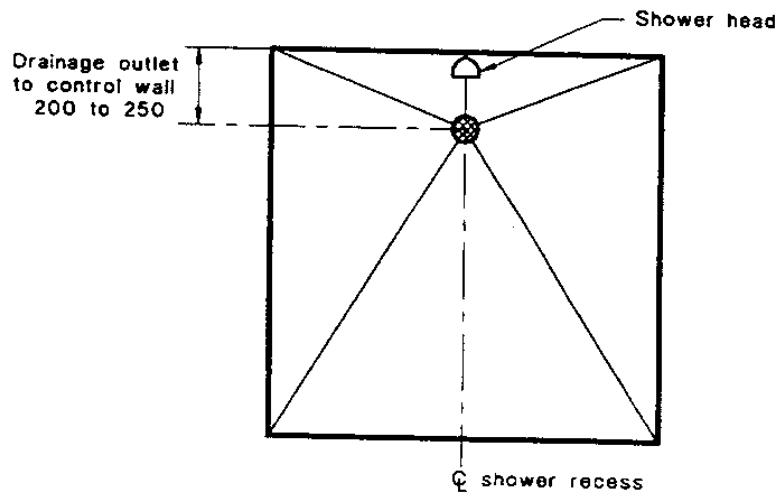

5 CAR PARKING

Applicable (Please tick)

Non-applicable (Please tick)

5.1	CAR PARKING <i>(Source: Australian Standard 1428.1 and AS 2890.1 and 2890.5)</i>	Complies	
		Yes	No

- | | | | |
|---|---|--------------------------|--------------------------|
| a | Are car parking spaces for people with disability provided at a rate shown in Appendix A – requirements for people with disabilities? | <input type="checkbox"/> | <input type="checkbox"/> |
| b | Are designated parking spaces close to accessible building entrances? | <input type="checkbox"/> | <input type="checkbox"/> |
| c | Are designated parking spaces connected by continuous unobstructed path of travel to the building? | <input type="checkbox"/> | <input type="checkbox"/> |
| d | Are spaces a minimum of 3200mm wide and 5400mm long? | <input type="checkbox"/> | <input type="checkbox"/> |
| e | Do parking spaces have unobstructed headroom of 2500mm? | <input type="checkbox"/> | <input type="checkbox"/> |
| f | Are parking spaces well lit, clearly linemarked on the ground and signposted with the international symbol? | <input type="checkbox"/> | <input type="checkbox"/> |

Note: Refer to Council's Off-street Parking Development Control Plan for overall parking requirements.

6 HEARING AUGMENTATION

Applicable (Please tick)

Non-applicable (Please tick)

6.1	HEARING AUGMENTATION	Complies	
		Yes	No

- | | | | |
|---|---|--------------------------|--------------------------|
| a | Where a system of hearing augmentation is required by the BCA, has a listening device to aid hearing impaired persons been installed? | <input type="checkbox"/> | <input type="checkbox"/> |
|---|---|--------------------------|--------------------------|

7 SIGNS

Applicable (Please tick)
Non-applicable (Please tick)

7.1 Signs
(Source: Australian Standard 1428.2 1992)

- | | | | |
|---|---|--------------------------|--------------------------|
| a | Are signs clear and legible and incorporate the appropriate international symbol (Figure 11)? | <input type="checkbox"/> | <input type="checkbox"/> |
| b | Are tactile signs provided in key locations including entrances, exits, lifts, sanitary facilities and parking areas? | <input type="checkbox"/> | <input type="checkbox"/> |
| c | Are directional signs provided at regular intervals and at least at every major change of direction? | <input type="checkbox"/> | <input type="checkbox"/> |
| d | Are the colour of the signs and lettering chosen to enhance the legibility of the signs and have a minimum 30% luminance contrast eg. White on black | <input type="checkbox"/> | <input type="checkbox"/> |
| e | Is the lettering simple, clear and easy to read of a size, which is visible from the appropriate distance and be of a contrasting colour to the background to assist people with vision impairment? | <input type="checkbox"/> | <input type="checkbox"/> |

Note: (a) to assist legibility, international pictograms of a contrasting colour shall be used in addition to words.

(b) tactile signs shall use enlarged raised print and Braille, internationally recognised symbols, and luminance contrast a minimum of 30% in accordance with AS 2899.1.

The table below shows height of letters for varying viewing distances.

Required Viewing Distance (m)	Minimum Height of letters (mm)
2	6
4	12
6	20
8	25
12	40
15	50
25	80
35	100
40	130
50	150

Source: *Building Access Outcomes Report prepared by Australian Building Codes (Refer to AS1744)*

Figure 11: International Symbols

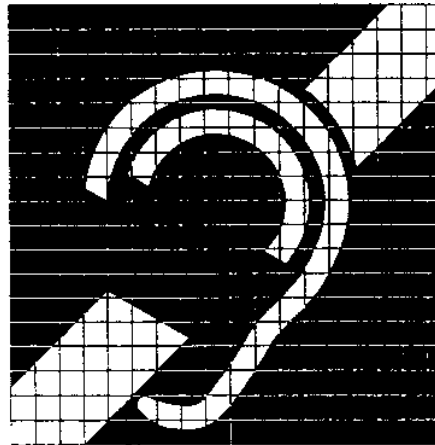

8 FLOOR, GROUND AND WALL SURFACES

Applicable (Please tick)

Non-applicable (Please tick)

8.1	Floor, Ground and Wall Surfaces (Source: Australian Standard 1428.2 1992)	Complies	
		Yes	No
a	On the required continuous accessible path of travel, are there slip resistant (particularly when wet) surfaces provided to floors, including showers and toilets?	<input type="checkbox"/>	<input type="checkbox"/>
b	Have tactile ground surface indicators been provided at the following locations:		
	❖ Stairways, escalators and ramps?	<input type="checkbox"/>	<input type="checkbox"/>
	❖ Kerb ramps and step ramps with appropriate luminance contrast?	<input type="checkbox"/>	<input type="checkbox"/>
	❖ Pedestrian crossings in high use vehicular areas eg car parks?	<input type="checkbox"/>	<input type="checkbox"/>
	❖ Vehicle pick-up and drop-off areas?	<input type="checkbox"/>	<input type="checkbox"/>
c	Are floor, ground and wall surfaces made with a low reflectivity material to avoid disorientating images for people with vision impairment?	<input type="checkbox"/>	<input type="checkbox"/>
d	Are permanent, durable and non-slip strips applied to non-complying surfaces?	<input type="checkbox"/>	<input type="checkbox"/>

Note: Tactile ground surface indicators can cause inconvenience to some people and therefore their use should be minimised. Appropriate design solution is to provide a continuous path of travel with minimal use of the indicators.